

# CERAMIC RESONATORS

## INTRODUCTION

### TO CERAMIC RESONATORS

This manual describes the theory and the application of ceramic resonators and is designed to help you use them effectively.

Ceramic resonators utilize the mechanical resonance of piezoelectric ceramics. Long years of experience in the design and mass production of piezoelectric ceramic filters have enabled Murata Electronics to develop and produce economical and highly reliable ceramic resonators as a stabilization component for oscillating circuits.

Advances in IC technology have made it possible to control various devices with a single LSI. Since their cost has been greatly reduced by expanded use in industrial equipment, as well as consumer electronics, it can be expected that the field of application will be expanded more in the future.

Resonators designed to provide a clock source for single chip microcomputers provide high stability and small size at substantial cost savings. Ceramic resonators currently find wide application in TV's, VCR's, automotive electronic devices, computers, telephones, copiers, cameras, voice synthesizers, communications equipment, remote controls, sewing machines, and toys.

#### GENERAL CHARACTERISTICS

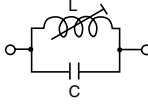
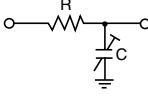
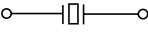
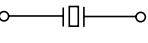
As a resonating device, quartz crystals are well-known. RC circuits and LC circuits are also well-known and often used to produce electrical resonance for oscillating circuits. Ceramic resonator technology is not as familiar to the design engineer. Following are the basic characteristics of the ceramic resonator:

- **High Stability of Oscillation Frequency**  
Oscillation frequency stability is between that of crystal resonators and LC or RC controlled oscillating circuits. The temperature coefficient for crystal resonators is  $10^{-6}/^{\circ}\text{C}$  maximum and approximately  $10^{-3}/^{\circ}\text{C}$  to  $10^{-4}/^{\circ}\text{C}$  for LC or RC oscillation circuits. Compared with these, the ceramic resonator has a TC of  $10^{-5}/^{\circ}\text{C}$  from  $-20^{\circ}\text{C}$  to  $+80^{\circ}\text{C}$ .
- **Small Size and Light Weight**  
The ceramic resonator is half the size of comparable devices.
- **Low price, Non-adjustable**  
Ceramic resonators are mass produced resulting in low cost, high stability and reliability.

Unlike RC or LC circuits, ceramic resonators utilize mechanical resonance. This means the resonator is not basically effected by external circuits or by fluctuations of the supply voltage.

Highly stable oscillation circuits can therefore be made without the need for adjustment. Fig.470-1 briefly describes the characteristics of various oscillator frequency control elements.

#### CHARACTERISTICS OF VARIOUS OSCILLATOR FREQUENCY CONTROL ELEMENTS—Fig. 470-1

Name	Symbol	Price	Size	Adjustment	Oscillation Frequency Initial Tolerance	Long-term Stability
LC		Inexpensive	Big	Required	$\pm 2.0\%$	Fair
RC		Inexpensive	Small	Required	$\pm 2.0\%$	Fair
Crystal Resonator		Expensive	Big	Not Required	$\pm 0.001\%$	Excellent
Ceramic Resonator		Inexpensive	Small	Not Required	$\pm 0.5\%$	Excellent

#### OSCILLATION MODE CHARACTERISTICS OF CERAMIC RESONATORS

The oscillation mode of a ceramic resonator varies with its resonant frequency. Fig. 470-2 shows this relationship.


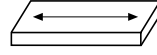




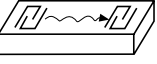
Vibration Mode	Frequency						
	1k	10k	100k	1M	10M	100M	1G
<b>Flexure Oscillation</b> 	Shaded	Shaded					
<b>Length-wise Oscillation</b> 			Shaded				
<b>Oscillation Area</b> 			Shaded				
<b>Radius Oscillation</b> 			Shaded				
<b>Thickness Oscillation</b> 				Shaded			
<b>Trapped Oscillation</b> 				Shaded	Shaded		
<b>Surface Acoustic Wave</b> 						Shaded	Shaded

Fig. 470-2 The Oscillation Mode vs. Frequency Range for Ceramic Resonators  
Note: Arrow signifies the direction of the vibrations.

# CERAMIC RESONATORS

## INTRODUCTION TO CERAMIC RESONATORS

### PRINCIPLES OF OPERATION FOR CERAMIC RESONATORS

#### Equivalent Circuit Constants

Fig. 471-2 shows the symbol for a ceramic resonator. The impedance and phase characteristics measured between the terminals are shown in Fig. 471-5. This figure illustrates that the resonator becomes inductive in the frequency range between the frequency  $f_r$  (resonant frequency), which provides the minimum impedance, and the frequency  $f_a$  (anti-resonant frequency), which provides the maximum impedance. It becomes capacitive in other frequency ranges. This means that the mechanical oscillation of a two-terminal resonator can be replaced with an equivalent circuit consisting of a combination of series and

parallel resonant circuits with an inductor  $L$ , a capacitor  $C$ , and a resistor  $R$ . In the vicinity of the resonant frequency, the equivalent circuit can be expressed as shown in Fig. 471-4.

The  $f_r$  and  $f_a$  frequencies are determined by the piezoelectric ceramic material and its physical parameters. The equivalent circuit constants can be determined from the following formulas:

$$f_r = 1/2\pi\sqrt{L_1C_1}$$

$$f_a = 1/2\pi\sqrt{L_1C_1C_0/(C_1 + C_0)} = F_r\sqrt{1 + C_1/C_0}$$

$$Q_m = 1/2\pi F_r C_1 R_1$$

( $Q_m$  = Mechanical Q)

Considering the limited frequency range of  $f_r \leq f \leq f_a$ , the impedance is given as  $Z = R_e + j\omega L_e$  ( $L_e \leq 0$ ) as

shown in Fig. 471-5. The ceramic resonator should operate as an inductor  $L_e$  (H) having the loss  $R_e$  ( $\Omega$ ).

Fig. 471-1 shows comparisons for equivalent circuit constants between a ceramic resonator and a quartz crystal resonator. Note there is a large difference in capacitance and  $Q_m$  which results in the difference of oscillating conditions when actually operated. The table in the appendix shows the standard values of equivalent circuit constants for each type of ceramic resonator.

Higher harmonics for other modes of oscillation exist other than the desired oscillation mode. These other oscillation modes exist because the ceramic resonator uses mechanical resonance. Fig. 471-6 shows these characteristics.

Frequency	Ceramic Resonator				Crystal			
	455kHz	2.50MHz	4.00MHz	8.00MHz	453.5kHz	2.457MHz	4.00MHz	8.00MHz
$L_1$ ( $\mu$ H)	$8.8 \times 10^3$	$1.0 \times 10^3$	385	72	$8.6 \times 10^3$	$7.2 \times 10^3$	$2.1 \times 10^3$	$1.4 \times 10^4$
$C_1$ (pF)	14.5	4.2	4.4	5.9	0.015	0.005	0.007	0.027
$C_0$ (pF)	256.3	33.3	36.3	39.8	5.15	2.39	2.39	5.57
$R_1$ ( $\Omega$ )	9.0	17.6	8.7	4.8	1060	37.0	22.1	8.0
$Q_m$	2734	912	1134	731	23000	298869	240986	88677
$\Delta F$ (kHz)	12	147	228	555	0.6	3	6	19

Fig. 471-1 Comparisons of equivalent Circuit Constants for Ceramic and Crystal Resonators

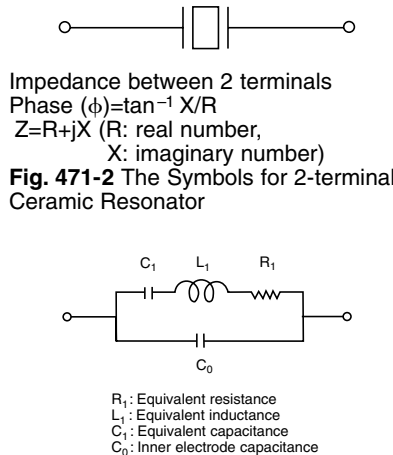


Fig. 471-3 Electrical Equivalent Circuit for a Ceramic Resonator

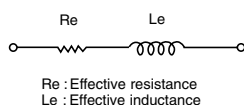


Fig. 471-4 Equivalent Circuit for a Ceramic Resonator in the Frequency Range of  $f_r \leq f \leq f_a$

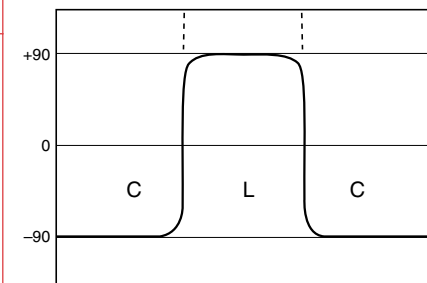
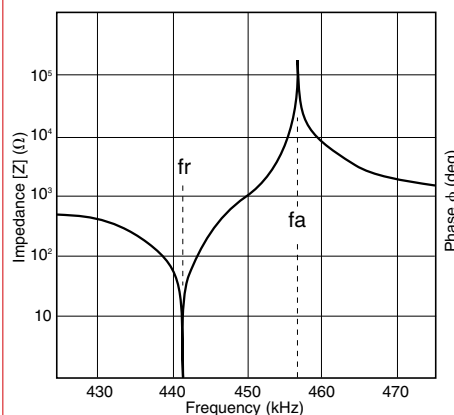


Fig. 471-5 Impedance and Phase Characteristics for Ceramic Resonators

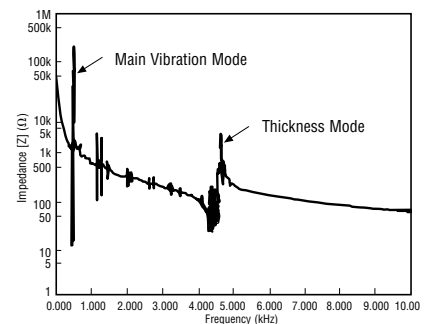


Fig. 471-6 Spurious Characteristics for a Typical Ceramic Resonator (CSB455E)

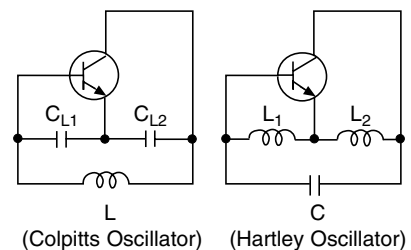


Fig. 471-7 Basic Configuration for an LC Oscillation Circuit

# CERAMIC RESONATORS INTRODUCTION TO CERAMIC RESONATORS

## Basic Oscillating Circuits

Generally, the oscillating circuits can be grouped into the following three types:

1. Positive feedback
2. Negative resistance element
3. Delay of transfer time or phase

In the case of ceramic resonators, quartz crystal resonators, and LC oscillators, positive feedback is the circuit of choice.

Among the positive feedback oscillation circuits using LC, the tuning type anti-coupling oscillation circuit, by the Colpitts and Hartley, are typically used. See Fig. 471-7.

In Fig. 471-7, a transistor, which is the most basic amplifier, is used.

The oscillation frequencies are approximately the same as the

resonance frequency of the circuit consisting of  $L$ ,  $C_{L1}$ , and  $C_{L2}$  in the Colpitts circuit or consisting of  $L_1$ ,  $L_2$  and  $C$  in the Hartley circuit. These frequencies can be represented by the following formulas.

### Colpitts Circuit

$$f_{OSC} = \frac{1}{2\pi} \sqrt{L \cdot \frac{C_{L1} \cdot C_{L2}}{C_{L1} + C_{L2}}}$$

### Hartley Circuit

$$f_{OSC} = \frac{1}{2\pi} \sqrt{C(L_1 + L_2)}$$

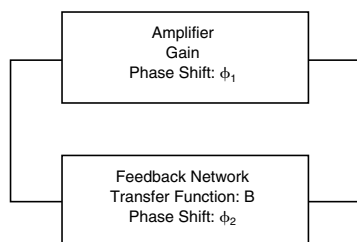
In a ceramic resonator oscillator, the inductor is replaced by a ceramic resonator, taking advantage of the fact that the resonator becomes inductive between resonant and anti-resonant frequencies. The most commonly used circuit is the Colpitts circuit.

The operating principle of these oscillation circuits can be seen in

Fig. 472-1. Oscillation occurs when the following conditions are satisfied. Loop gain:  $G = \alpha \cdot \beta \geq 1$

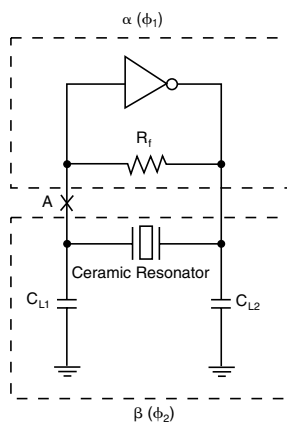
Phase amount  $\phi_T = \phi_1 + \phi_2 = 360^\circ \cdot n$  ( $n=1,2,\dots$ )

In a Colpitts circuit, an inversion of  $\phi_1 = 180^\circ$  is used, and it is inverted more than  $\phi_2 = 180^\circ$  with  $L$  and  $C$  in the feedback circuit. The operation with a ceramic resonator can be considered as the same.

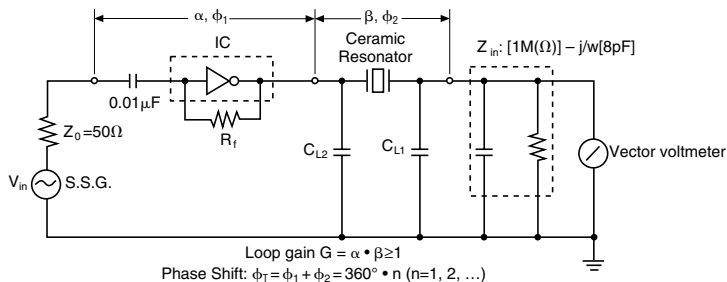


Oscillating conditions  
Loop gain  $G = \alpha \cdot \beta \geq 1$   
Phase Shift:  $\phi_T = \phi_1 + \phi_2 = 360^\circ \cdot n$  ( $n=1, 2, \dots$ )

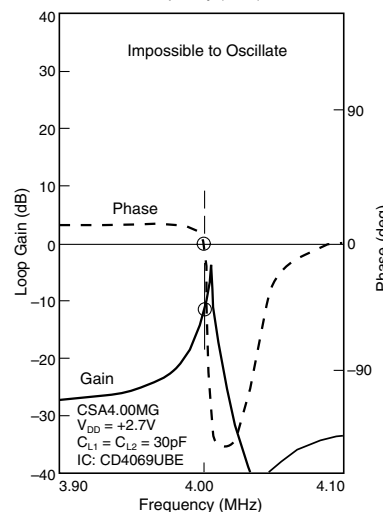
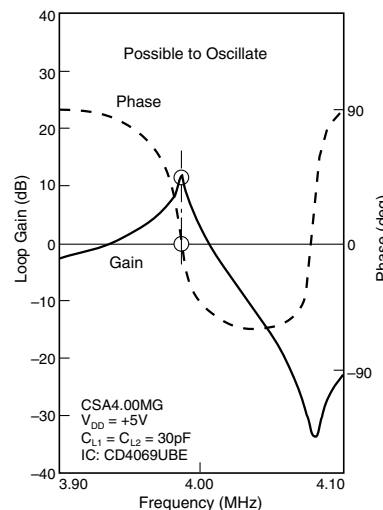
**Fig. 472-1** Principle of Oscillation



**Fig. 472-2** Basic Oscillation Circuit with Inverters

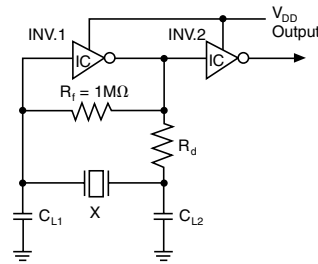


**Fig. 472-3** Measuring Circuit Network for Loop-Gain and Phase Shift

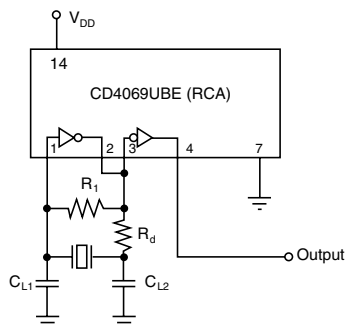


**Fig. 472-4** Measured Results of Loop Gain and Phase Shift

**Fig. 473-1** Basic Oscillation Circuit with CMOS Inverter

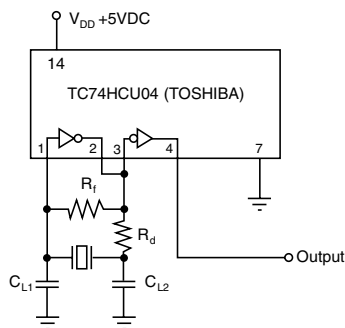


IC : CD4069UBE (MOS)  
X : Ceramic Resonator  
 $C_{L1}$ ,  $C_{L2}$  : Loading Capacitance  
 $R_d$  : Damping Resistance



**Fig. 473-2** CMOS Standard Circuit

Ceramic Resonator	Frequency Range	$V_{DD}$	Circuit Constant			
			$C_{L1}$	$C_{L2}$	$R_f$	$R_d$
CSB Series	375 to 429kHz	+ 5V	120pF	470pF	1M	0
	430 to 699kHz		100pF	100pF	1M	0
	700 to 1250kHz		100pF	100pF	1M	5.6K
CSA $\square$ MK	1.251 to 1.799MHz	+ 5V	30pF	30pF	1M	0
CSA $\square$ MG	1.80 to 6.30MHz	+ 5V	30pF	30pF	1M	0
CSA $\square$ MTZ	6.31 to 13.0MHz	+12V	30pF	30pF	1M	0
GST $\square$ MG	1.80 to 2.44MHz	+ 5V	30pF	30pF	1M	0
GST $\square$ MGW	2.45 to 6.30MHz	+ 5V	30pF	30pF	1M	0
GST $\square$ MTW	6.31 to 13.0MHz	+12V	30pF	30pF	1M	0



**Fig. 473-3** HC-MOS Standard Circuit

Ceramic Resonator	Frequency Range	$V_{DD}$	Circuit Constant			
			$C_{L1}$	$C_{L2}$	$R_f$	$R_d$
CSA $\square$ MK040	1.251 to 1.799MHz	+5V	100pF	100pF	1M	1.0K
CSA $\square$ MG040	1.80 to 6.30MHz	+5V	100pF	100pF	1M	680
CSA $\square$ MTZ040	6.31 to 13.0MHz	+5V	100pF	100pF	1M	220
CSA $\square$ MXZ040	12.00 to 19.99MHz	+5V	30pF	30pF	1M	0
	20.00 to 25.99MHz	+5V	15pF	15pF	1M	0
	26.00 to 60.00MHz	+5V	5pF	5pF	1M	0
GST $\square$ MG040	1.80 to 2.44MHz	+5V	—	—	1M	680
GST $\square$ MGW040	2.45 to 6.30MHz	+5V	—	—	1M	680
GST $\square$ MTW040	6.31 to 13.0MHz	+5V	—	—	1M	220
GST $\square$ MXW040	13.01 to 60.00MHz	+5V	—	—	1M	0

## Typical Oscillation Circuit

The most common oscillator circuit for a ceramic resonator is a Colpitts circuit. The design of the circuit varies with the application and the IC to be used, etc. Although the basic configuration of the circuit is the same as that of a crystal controlled oscillator, the difference in mechanical Q results from a difference in circuit constants. Some typical examples follow.

## Design Considerations

It is becoming more common to configure the oscillation circuit with a digital IC, using an inverter gate. Fig. 473-1 shows the configuration of a basic oscillation circuit with a CMOS inverter.

INV.1 operates as an inverting amplifier for the oscillating circuit. INV.2 is used as a waveform shaper and also acts as a buffer for the output.

The feedback resistance  $R_f$  provides negative feedback around the inverter so that oscillation will start when power is applied.

If the value of  $R_f$  is too large and the insulation resistance of the input inverter is low, then oscillation will stop due to the loss of loop gain. Also, if  $R_f$  is too great, noise from other circuits can be introduced into the oscillation circuit. Obviously, if  $R_f$  is too small, loop gain will be decreased. An  $R_f$  of  $1M\Omega$  is generally used with a ceramic resonator.

Dumping resistor  $R_d$  has the following function although it is sometimes omitted. It makes the coupling between the inverter and the feedback circuit loose; thereby, decreasing the load on the output side of the inverter. In addition, the phase of the feedback circuit is stabilized. It also provides a means of reducing the gain at higher frequencies, thus preventing the possibility of spurious oscillation.

## Loading Capacitance

Load capacitance  $C_{L1}$  and  $C_{L2}$  provide a phase lag of  $180^\circ$ . These values should be properly selected depending on the application, the IC used and the frequency. If  $C_{L1}$  and  $C_{L2}$  are lower values than necessary, the loop gain at high frequencies is increased, which in turn increases the probability of spurious oscillation. This is particularly likely around 4-5MHz where the thickness vibration mode lies.

Oscillation frequency ( $f_{OSC}$ ) in this circuit is expressed approximately by the following equation.

$$f_{OSC} = f_r \sqrt{1 + (C_1/C_0 + C_L)}$$

Where,  $f_r$ : Resonance frequency of the ceramic resonator.

$C_1$ : Equivalent series capacitance of the ceramic resonator.

$C_0$ : Equivalent parallel capacitance of the ceramic resonator.  $C_L = C_{L1} \cdot C_{L2} / (C_{L1} + C_{L2})$

This clearly shows that the oscillation frequency is influenced by the loading capacitance. Caution should be taken in defining its value when a tight tolerance for oscillation frequency is required.

## CMOS Inverter

A CMOS inverter can be used as the inverting amplifier; the one-stage type of the 4069 CMOS group is most useful. Because of excessive gain, ring oscillation of CR oscillation is a typical problem when using the three-stage buffer type inverter, such as the 4069 group. Murata Electronics employs the RCA CD4069UBE as a CMOS standard circuit, as shown in Fig. 473-2.

## HC-MOS Inverter Circuit

Recently, the high speed CMOS (HC-MOS) is increasingly being used for circuits allowing high speed and low power consumption for microprocessors.

There are two types HC-MOS inverters: the un-buffered 74HCU series and the 74HC series with buffers. The 74HCU system is optimum for ceramic resonators. See Fig. 473-3.

## Frequency Correlation

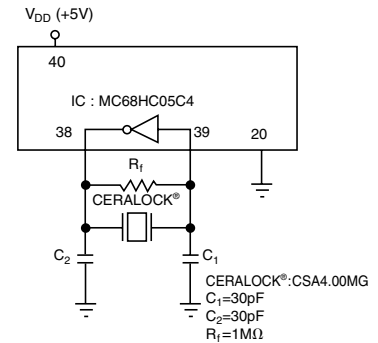
The oscillator circuits shown on page 477 are Murata standard test circuits. The inverters used in these circuits are widely accepted as industry standards because their characteristics are representative of those found in microprocessors within the same family (CMOS/HC-MOS). Naturally, applications will differ in what IC is used, and as can be expected, oscillator circuit characteristics will vary from IC to IC.

Usually, this variation is negligible and a ceramic resonator part number can be selected simply by classifying the processor as CMOS or HC-MOS.

Given that the standard Murata ceramic resonators are 100%

frequency of oscillation sorted to the test circuits on page 477, it is relatively easy to correlate the frequency of oscillation of our standard circuit to that of a customer specified circuit.

For example, if the microprocessor being used is a Motorola 6805 at a frequency of 4MHz, then the correct Murata part number would be CSA4.00MG (frequency sorted to the CD4069UBE CMOS test circuit). Circuit parameters should be selected as below:



By actually setting up this circuit as well as the standard test circuit shown in Fig. 473-2, it is possible to establish the average shift that can be expected when using the CSA4.00MG with a 6805 processor. The actual data is shown below:

## Frequency Correlation Data

Resonator	IC: MC6805C4	IC: CD4069UBE
Sample #		
1	3994.21	3991.80
2	3997.49	3995.46
3	4000.87	3997.96
4	3998.18	3995.96
5	4001.09	3998.87
X	3998.37	3996.01

From this data, it is possible to predict that the standard Murata CSA4.00MG resonator will have an approximate +0.06% frequency shift from the original 4.00MHz  $\pm 0.5\%$  initial tolerance. This is of course negligible shift and will not affect circuit performance in any way.

## CHARACTERISTICS OF CERAMIC RESONATOR OSCILLATION

The following describes the general characteristics of oscillation in the basic circuit of Fig. 475-1. Contact your local Murata Electronics Sales Office for detailed characteristics of oscillation with specific kinds of IC's and LSI's.

Fig. 475-2 shows examples of actual measurements for stability of oscillation frequency. The stability against temperature change is  $\pm 0.3$  to  $0.5\%$  within a range of  $-20^{\circ}\text{C}$  to  $+80^{\circ}\text{C}$ , although it varies slightly depending on the ceramic material. Influences

of load capacitance ( $C_{L1}$ ,  $C_{L2}$ ) on the oscillation frequency is relatively high as can be calculated from the formula for  $f_{OSC}$  (see pg. 472). The  $f_{OSC}$  varies by approximately  $\pm 0.1\%$  because of the capacitance deviation of  $\pm 0.1\%$  in the working voltage range. The  $f_{OSC}$  also varies with the characteristics of the IC.

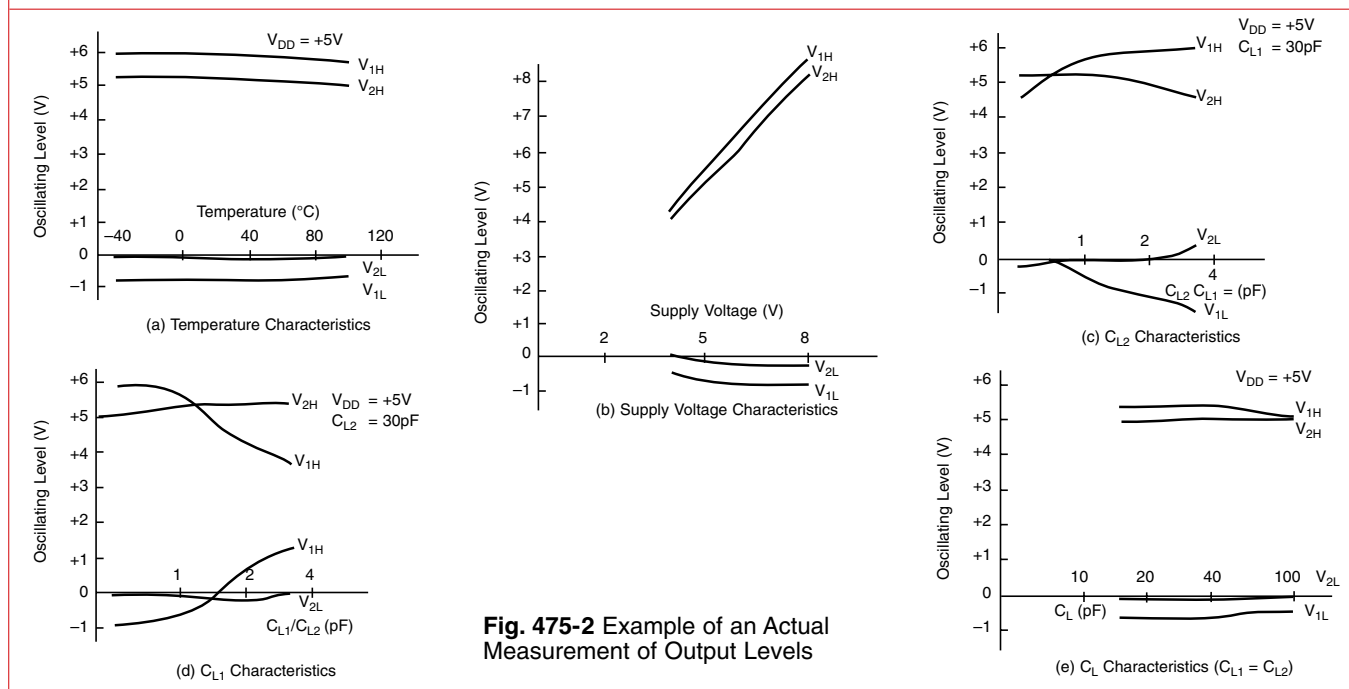
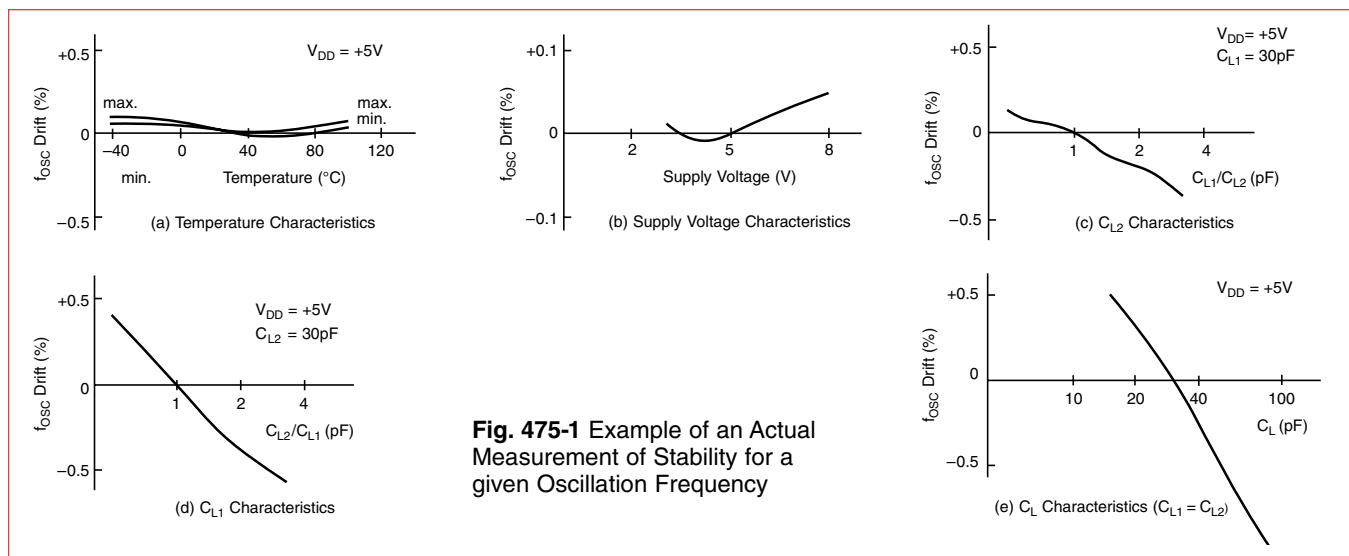
## SUPPLY VOLTAGE VARIATION CHARACTERISTICS

See Fig. 475-1 for an example of an actual measurement of stability for a given oscillation frequency.

## OSCILLATION LEVEL

Fig. 475-2 shows examples of actual measurements of the oscillation level

against temperature, supply voltage, and load capacitance ( $C_{L1}$ ,  $C_{L2}$ ). The oscillating level is required to be stable over a wide temperature range, and temperature characteristics be as flat as possible. This change is linear with supply voltage unless the IC has an internal constant voltage power source.



CERAMIC RESONATORS

## OSCILLATION RISE TIME

Oscillation rise time means the time when oscillation develops from a transient area to a steady area at the time the power to the IC is activated. With a ceramic resonator, it is defined as the time to reach 90% of the oscillation level under steady conditions as shown in Fig. 476-1.

Rise time is primarily a function of oscillating circuit design. Generally, smaller loading capacitance, a higher

frequency ceramic resonator, and a smaller size of ceramic resonator will cause a faster rise time. The effect of load capacitance becomes more apparent as the capacitance of the resonator decreases. Fig. 476-2 shows an actual measurement of rise time against load capacitance ( $C_L$ ) and supply voltage. It is noteworthy that the rise time is one or two decades faster for a ceramic resonator than for a quartz crystal. (This point is graphically illustrated in Fig. 476-3.)

## STARTING VOLTAGE

Starting voltage means the minimum supply voltage at which an oscillating circuit can operate. Starting voltage is affected by all circuit elements. It is determined mostly by the characteristics of the IC. Fig. 476-4 shows an example of an actual measurement for the starting voltage characteristics against the loading capacitance.

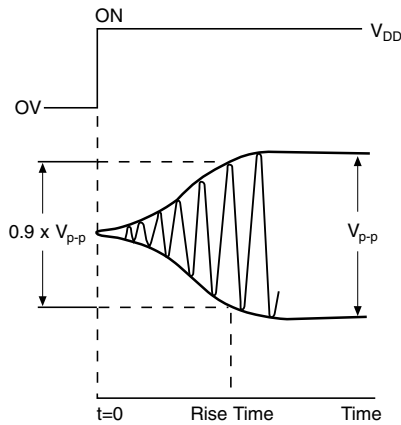
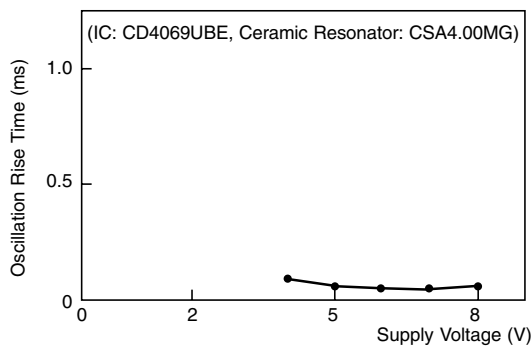
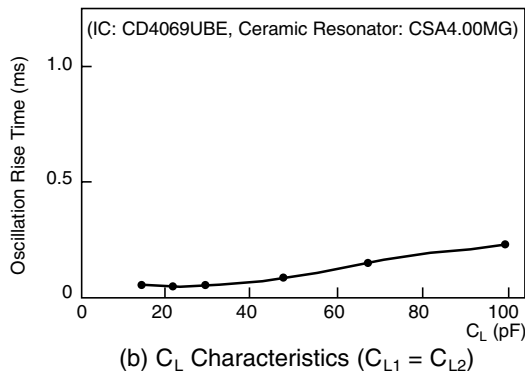


Fig. 476-1 Definition of Rise Time



(a) Supply Voltage Characteristics



(b)  $C_L$  Characteristics ( $C_{L1} = C_{L2}$ )

Fig. 476-2 Example of Actual Measurements for the Characteristics of Oscillation Rise Time

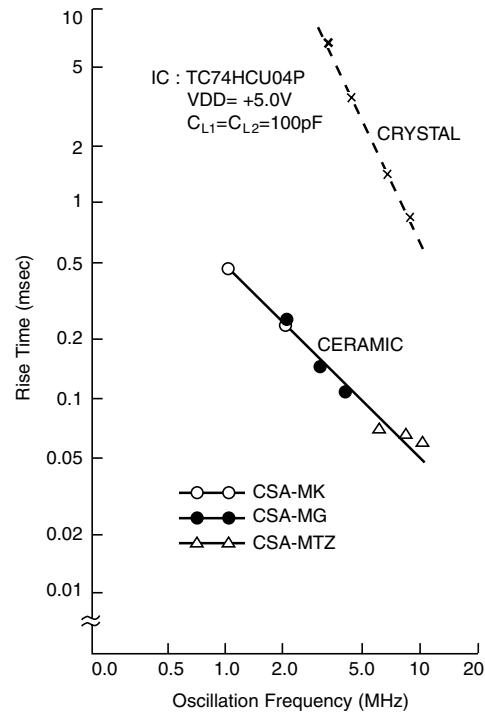


Fig. 476-3 Rise Time vs. Oscillation Frequency for Both Ceramic and Crystal Resonator

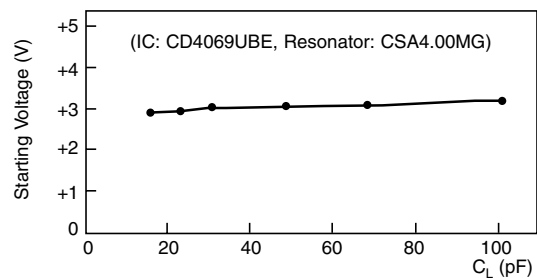


Fig. 476-4 Starting Voltage Characteristics against  $C_L$  ( $C_{L1} = C_{L2}$ )

## Circuits for Various IC/LSI

Ceramic resonators are being used in a wide range of applications in combination with various kinds of IC's by making good use of the previously mentioned features. Following are a few examples of actual applications.

### Applications for Microprocessors

Ceramic resonators are optimum as a stable oscillating element for various kinds of microprocessors: 4 bit, 8 bit, and 16 bit.

As the general frequency tolerance required for the reference clock of microprocessors is  $\pm 2\%$ – $3\%$ , standard units meet this requirement. Consult with Murata Electronics or LSI manufacturers about circuit constants because they vary with frequency and the LSI circuit being used. Fig. 477-1 shows an application with a 4 bit microprocessor, and Fig. 477-2 shows an application with an 8 bit microprocessor.

### Remote Control IC

Remote controls have increasingly become a common feature for TV's stereos, VCR's, and air conditioners. Oscillation frequency is normally 3.2-4.0MHz, with 3.64MHz being the most popular. This 3.64MHz is divided by a carrier signal generator so that approximately 38kHz of carrier is generated.

### VCO (Voltage Controlled Oscillator) Circuits

VCO circuits are used in TV's and audio equipment because the signals need to be processed in synchronization with pilot signals transmitted from broadcasting

stations. Oscillation circuits, such as LC and RC were originally used; however, ceramic resonators are now used since they require no adjustment and have superior stability over the older type circuits.

Resonators for VCO applications are required to have a wide variable frequency range. We supply ceramic resonators with specially designed ceramic materials for VCO applications.

### TV Horizontal Oscillator Circuits

Fig. 477-4 shows application example of a horizontal oscillator circuit.

### Stereo Modulation Circuits

Fig. 477-5 is an FM-MPX decoder.

### Telephone Dialers

Electronic telephones are becoming increasingly important as a highly advanced communication terminal. A tendency toward changing to tone dialers from pulse dialers has become apparent in order to make use of a telephone key pad for effective data transmission.

Allocated tone frequencies in columns and rows determine specific key signals by using a combination to two tones. It is mandatory to observe an overall frequency tolerance of  $\pm 1.5\%$ , under any condition, since IC's normally have a division error of 0.1% to 0.75%. A maximum frequency tolerance of  $\pm 0.6\%$  is allowed for the oscillator in a tone dialer.

In order to satisfy this frequency accuracy requirement, Murata has designed the 3.58MHz ceramic resonator (CSA3.58 MG300) series specifically prepared for

each IC. Fig. 477-6 shows an example of a ceramic resonator in a tone dialer circuit.

## MISCELLANEOUS

Other than the above mentioned uses, ceramic resonators are widely used with IC's for voice synthesis and clock generation.

The tables shown on the following page illustrate the variety of applications and IC's that can utilize ceramic resonators.

For general timing control applications, oscillation frequency is usually selected by the user based on the IC manufacturer's recommended operating frequency range. The selection of this frequency with a given IC will dictate what circuit values and which ceramic resonator will be appropriate. Please contact your local Murata sales representative when selecting a ceramic resonator part number.

As mentioned earlier, there are many applications for ceramic resonators. Some of the more application specific oscillator circuits require that unique ceramic resonators be developed for that application and IC. This IC/application dependency is illustrated in Tables 478-1 and 478-2. When ordering or designing special function resonators, please contact your local sales representative to get details on appropriate part number designations.

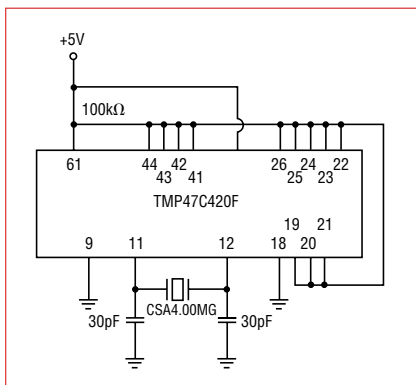


Fig. 477-1 TMP47C420F (TOSHIBA)

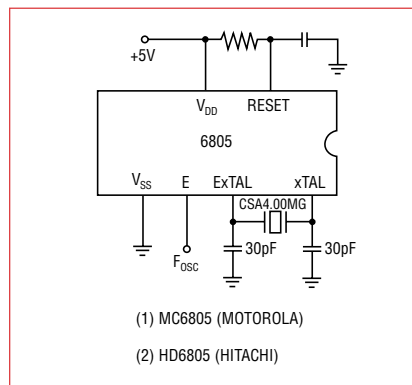


Fig. 477-2 6805s by Various Manufacturers (Timing Control)

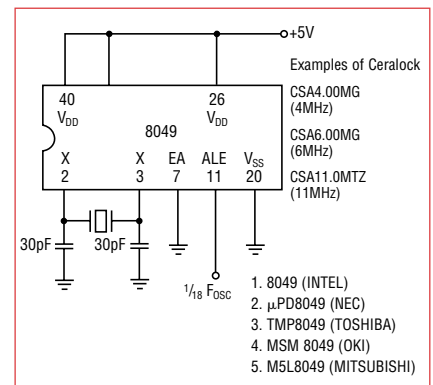


Fig. 477-3 By Various Manufacturers (Timing Control, 8 bit)

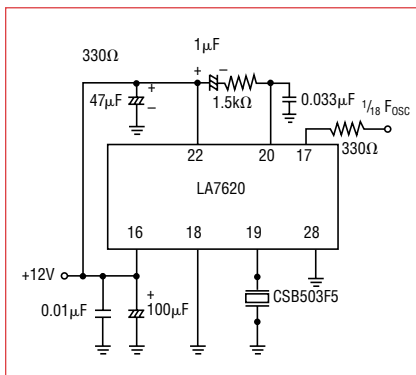


Fig. 477-4 Application with LA7620 (SANYO)

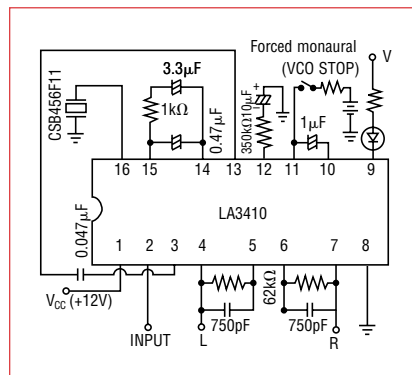


Fig. 477-5 Application with LA3410 (SANYO)

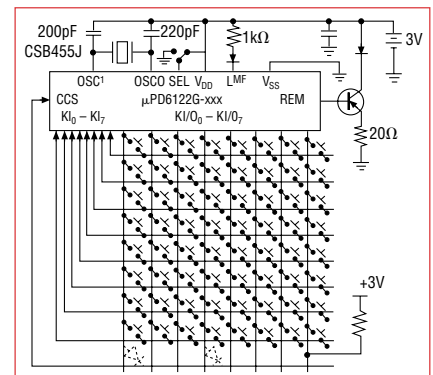


Fig. 477-6  $\mu$ PD6122G (NEC)

**TABLE 478-1  
DTMF IC'S/APPLICATION DEPENDENT RESONATORS**

<b>Mitel</b>	MT5089XC MT8870BE MT8870CE MT8880AP	CSA3.58MG300ABC CSA3.58MG300AB CSA3.58MG300A CSA3.58MG300FGA
<b>Motorola</b>	MC145412 MC145436 MC145513	CSA3.58MG300ABC CSA3.58MG300GA CSA3.58MG300BCD
<b>N.S.</b>	TP5088N TP5089N TP53130N	CSA3.58MG300BCD CSA3.58MG300BCD CSA3.58MG300GAB
<b>T.I.</b>	TCM5087N TCM5089 TCM5094	CSA3.58MG300DE CSA3.58MG300DE CSA3.58MG300DE
<b>A.M.I.</b>	S25089 S2559E S25569B S2569J S2579 S2859 S2860	CSA3.58MG300ABC CSA3.58MG300ABC CSA3.58MG300ABC CSA3.58MG300GAB CSA3.58MG300GAB CSA3.58MG300ABC CSA3.58MG300ABC
<b>SGS</b>	EFG71891 MK53721N MK53761N MK53762N MK53721 MK53731 MK5375	CSA3.58MG300FG CSA3.58MG300ABC CSA3.58MG300ABC CSA3.58MG300ABC CSA3.58MG300ABC CSA3.58MG300ABC CSA3.58MG300CDE
<b>Philips</b>	PCD3310 PCD3343 PCD3347	CSA3.58MG310VA CSA3.58MG310VA CSA3.58MG310VA
<b>Plessey</b>	MV5087 MV5089 MV8870	CSA3.58MG300GAB CSA3.58MG300BCD CSA3.58MG300B

**TABLE 478-2  
VCO IC'S/APPLICATION DEPENDENT RESONATORS**

<b>Motorola</b>	MC13020P MC13022P	CSA3.60MGF102 CSA3.60MGF103	AM Stereo
	MC1378	CSA4.03MTZF102	TV
<b>SGS</b>	TEA2029C TDA8181	CSB503F21 CSB503F21	TV
<b>Philips</b>	TDA1591 V3*	CSB456JF932	FM Multiplex
<b>NEC</b>	uPC1340 uPC1348	CSB456F19 CSB456F24	FM Multiplex
	uPC1401C uPC1820CA	CSB503F2 CSB503F23	TV
<b>Sanyo</b>	LA3410 LA3430 LA1886/LA1860/61	CSB456F11 CSB456F15 CSB456F23	FM Multiplex
	LA7620 LA7650 LA7670	CSB503F5 CSB503F15 CSB503F45	TV
<b>Toshiba</b>	TA7413AP/8132Z TA8122AN	CSB456F14 CSB456F16	FM Multiplex
	TA7777P TA8601AN/TA8783 TA8719N/TA8725N	CSB503F10 CSB503F30 CSB503F30	TV

## EQUIVALENT CIRCUIT CONSTANTS

Ceralock Type	Fr (kHz)	Fa (kHz)	R1 (Ω)	L1 (mH)	C1 (pF)	Co (pF)
CSB200D	195.1	200.6	5.0	11.351	58.652	1015.224
CSB250D	244.3	251.3	8.9	12.188	34.826	596.642
CSB300D	292.8	302.2	7.1	9.461	31.254	477.295
CSB400P	388.5	402.4	6.2	6.704	25.046	344.364
CSB455E	443.9	457.3	10.1	7.68	16.74	272.76
CSB500E	487.2	503.2	8.5	7.163	14.907	222.824
CSB600P	586.5	604.2	11.8	6.186	11.912	194.269
CSB700J	682	706.5	11.1	5.387	10.068	146.862
CSB1000J	978.5	1013.3	13.7	4.441	5.958	82.481
CSB1200J	1179.6	1220.8	45.4	4.533	4.018	56.489
CSB456F11	436.6	457.9	11.4	4.163	31.924	320.378
CSB456F14	435.9	457.4	11	3.947	33.785	333.517
CSB500F2	506.1	549.8	8.5	1.321	74.896	415.585
CSB500F9	489	543.9	27.9	0.909	116.569	490.913
CSB503F2	509.5	554	8.5	1.246	78.333	429.017
CSB912JF103	851.8	920.7	23.1	1.344	25.971	154.401
CSB912JF104	853	925.3	20.7	1.247	27.909	157.875
CSK400J	397	405	116.3	50.264	3.197	79.006
CSKCC455E	451.3	459.5	144.5	46.912	2.651	72.895
CSA1.500MK	1466.3	1523.6	47.1	4.612	2.554	32.051
CSA2.00MG	1922.9	2046.7	18.3	1.397	4.908	36.942
CSA2.50MG	2391.4	2575	17.3	0.755	5.867	36.786
CSA3.00MG	2856.1	3083.5	12.9	0.439	7.073	42.741
CSA3.58MG	3424.5	3670.2	6.7	0.361	5.993	40.324
CSA4.00MG	3812.8	4118.6	6.8	0.284	6.125	36.719
CSA4.19MG	4008	4310.4	5.1	0.266	5.948	37.978
CSA5.00MG	4801.3	5133.6	4.9	0.217	5.046	35.692
CSA6.00MG	5750.8	6176.7	5.6	0.154	4.987	32.469
CSTS0400MG03	3372.5	3722.5	8.6	0.474	4.694	21.5
CSTS0358MG03	3818	4138	10.8	0.534	3.254	18.63
CSTS0500MG03	4757.5	5190	8.2	0.34	3.288	17.296
CSTS0600MG03	5760	6305	7.5	0.227	3.367	16.991
CSTS0800MG03	7667.5	8282.5	8.5	0.137	3.147	18.863
CSTC2.00MG	1950.6	2098	94.9	4.651	1.431	9.124
CSTC2.50MG	2433.9	2638	75	2.095	2.021	11.612
CSTC3.00MG	2877.5	3098.9	10	0.779	3.931	24.598
CSTCC3.58MG	3488.7	3723.2	38	2.072	1.014	7.228
CSTCC4.00MG	3796	4166	8.6	0.476	3.689	18.045
CSTCC5.00MG	4746.8	5100	13.4	0.358	3.144	20.37
CSTCC6.00MG	5725	6250	9.9	0.232	3.326	17.337
CSTCC8.00MG	7585	8340	6.9	0.111	3.969	18.992
CSTCC10.0MG	9530	10465	6.3	0.081	3.459	16.802
CSA8.00MTZ	7650.9	8247.6	4.5	0.068	6.419	39.6
CSA10.0MTZ	9628.7	10357.2	4.6	0.054	5.074	32.313
CSA11.0MTZ	10586.9	11403.8	5.3	0.043	5.245	32.784
CSA12.0MTZ	11511.2	12348.5	5.8	0.034	5.603	67.196
CSACV10.0MTJ	9539.3	10102.9	6.3	0.061	4.565	37.515
CSACV12.0MTJ	11408.1	12107.3	5.3	0.035	5.499	43.527
CSA16.00MXZ040	15966.7	16067.4	14.2	0.564	0.176	13.922
CSA20.00MXZ040	19929.6	20055.3	13.3	0.493	0.129	10.217
CSA27.00MXZ040	26930.8	27087.1	14.8	0.407	0.086	7.365
CSA30.00MXZ040	29893.1	30060.8	12.7	0.31	0.091	8.163
CSA33.86MXZ040	33766.3	33921.1	15.1	0.26	0.085	9.273
CSA40.00MXZ040	39932.2	40090.8	15.1	0.216	0.073	9.314
CSA50.00MXZ040	49918.6	50102.6	15.8	0.143	0.071	9.572
CSA60.00MXZ040	59973.2	60190	26.7	0.128	0.055	7.834
CSACV16.00MXJ040	15934.1	16030.1	14.4	0.651	0.153	12.685
CSACV20.00MXJ040	19957.8	20073.4	13.5	0.471	0.135	11.636
CSACV27.00MXJ040	26916.8	27066.2	13.6	0.315	0.111	9.967
CSACV30.00MXJ040	29912.3	30069.8	12.6	0.272	0.104	9.867
CSACV33.86MXJ040	33779.2	33952.9	11.7	0.213	0.104	10.126
CSACV40.00MXJ040	39917.8	40112.5	14.3	0.217	0.073	7.548
CSACV50.00MXJ040	49903.4	50127	15.1	0.169	0.059	6.72
CSACV60.00MXJ040	59913	60216.4	23	0.164	0.043	4.315
CSACW1600MX03	15982.8	16026.7	86.4	1.069	0.093	16.876
CSACW200MX03	19955.2	20042.3	32.7	0.629	0.101	11.557
CSACW2700MX03	26952.3	27026.8	19	0.364	0.096	17.327
CSACW3386MX03	33822.6	33914.2	16.3	0.253	0.088	16.131
CSACW4000MX03	39913.5	40037.1	13.9	0.217	0.072	11.875
CSACW5000MX03	49949.6	50083.1	16.4	0.177	0.056	10.843
CSTCV14.32MXJ0H4	—	—	27.8	1.04	0.1193	8.55

The equivalent circuit constants are not the guaranteed value but the standard value.  
Available as standard through authorized Murata Electronics Distributors.