

YXA SERIES

105°C Miniaturized

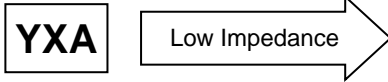

- YXF
- YXG
- JXA
- JXB



◆ SPECIFICATIONS

Items	Characteristics													
Category Temperature Range	-55~+105°C	-40~+105°C	-25~+105°C											
Rated Voltage Range	6.3~100V.DC	160~250V.DC	350~450V.DC											
Capacitance Tolerance	±20%(20°C, 120Hz)													
Leakage Current(MAX)	6.3~100V.DC	160~450V.DC												
	I=0.01CV or 3μA whichever is greater. (After 2 minutes application of rated voltage)	CV≤1000	CV>1000											
		I=0.1CV+40μA (1minute) I=0.03CV+15μA (5minutes)	I=0.04CV+100μA (1minute) I=0.02CV+25μA (5minutes)											
I=Leakage Current(μA) C=Rated Capacitance(μF) V=Rated Voltage(V)														
Dissipation Factor(MAX)	Rated Voltage (V) 6.3 10 16 25 35 50 63 100 160 200 250 350 400 450 (20°C, 120Hz)													
	tanδ 0.26 0.22 0.18 0.16 0.14 0.12 0.10 0.08 0.20 0.20 0.20 0.24 0.24 0.24													
When rated capacitance is over 1000μF, tanδ shall be added 0.02 to the listed value with increase of every 1000μF.														
Endurance	After life test with rated ripple current at conditions stated in the table below, the capacitors shall meet the following requirements.													
	Capacitance Change	Within ±25% of the initial value.											Case Dia	Life Time (hrs)
	Dissipation Factor	Not more than 200% of the specified value.											φD≤8	1000
	Leakage Current	Not more than the specified value.											φD=10	2000
φD≥12.5 3000														
Low Temperature Stability Impedance Ratio(MAX)	Rated Voltage (V) 6.3 10 16 25 35 50 63 100 160 200 250 350 400 450 (120Hz)													
	Z(-25°C)/Z(20°C) 4 3 2 2 2 2 2 2 3 3 3 6 6 6													
	Z(-40°C)/Z(20°C) 8 6 4 4 3 3 3 3 - - - - -													

◆ DIMENSIONS

(mm)

◆ MULTIPLIER FOR RIPPLE CURRENT

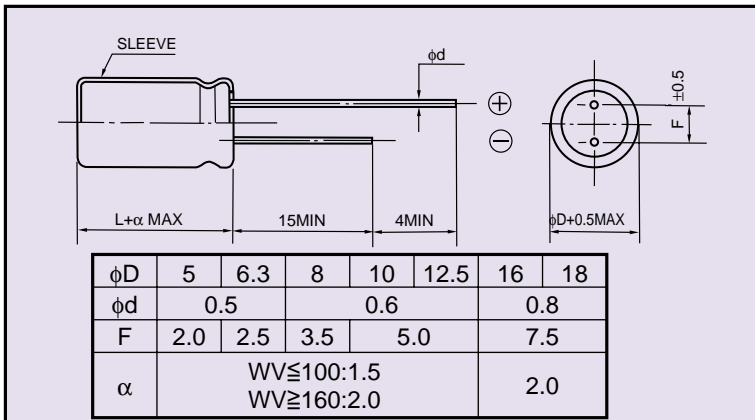

(1) Frequency coefficient

Frequency (Hz)	60(50)	120	500	1k	10k≤
0.1~47μF	0.80	1.00	1.20	1.30	1.50
100~1000μF	0.80	1.00	1.10	1.15	1.20
2200~22000μF	0.80	1.00	1.05	1.10	1.15

(2) Temperature coefficient

Ambient Temperature (°C)	105	85	65≥
Coefficient	1.0	1.7	2.1

◆ PART NUMBER

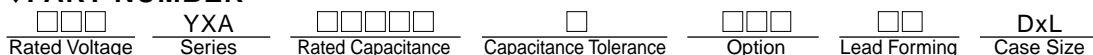



MINIATURE ALUMINUM ELECTROLYTIC CAPACITORS

YXA

◆ STANDARD SIZE, RATED RIPPLE CURRENT

Size ϕ DxL(mm), Ripple Current (mA r.m.s./105°C, 120Hz)

WV(V.DC) Cap(μ F)	6.3 (0J)		10 (1A)		16 (1C)		25 (1E)		35 (1V)		50 (1H)		63 (1J)	
	Size	Ripple	Size	Ripple	Size	Ripple	Size	Ripple	Size	Ripple	Size	Ripple	Size	Ripple
0.1											5x11	1		
0.15											5x11	1.5		
0.22											5x11	2.5		
0.33											5x11	4		
0.47											5x11	7		
1											5x11	13		
2.2											5x11	20		
3.3											5x11	25		
4.7											5x11	32		
10											5x11	47	5x11	48
22									5x11	64	5x11	70	5x11	80
33							5x11	69	5x11	77	5x11	94	6.3x11	100
47					5x11	80	5x11	84	5x11	100	6.3x11	115	6.3x11	140
100	5x11	96	5x11	105	5x11	130	6.3x11	140	6.3x11	170	8x11.5	200	10x12.5	230
220	5x11	160	6.3x11	175	6.3x11	220	8x11.5	240	10x12.5	300	10x12.5	360	10x16	390
330	6.3x11	210	6.3x11	235	8x11.5	270	10x12.5	335	10x12.5	400	10x16	470	10x20	540
470	6.3x11	275	8x11.5	295	8x11.5	375	10x12.5	440	10x16	525	10x20	600	12.5x20	700
1000	8x11.5	460	10x12.5	540	10x16	640	10x20	740	12.5x20	865	12.5x25	1060	16x25	1200
2200	10x20	775	10x20	860	12.5x20	1050	12.5x25	1230	16x25	1370	16x35.5	1600	18x35.5	1650
3300	10x20	985	12.5x20	1100	12.5x25	1300	16x25	1500	16x35.5	1680	18x35.5	1780		
4700	12.5x20	1150	12.5x25	1350	16x25	1650	16x31.5	1800	18x35.5	1920				
6800	12.5x25	1480	16x25	1700	16x31.5	1900	18x35.5	2050						
10000	16x25	1700	16x35.5	1950	18x35.5	2070								
15000	16x35.5	2090	18x35.5	2180										
22000	18x40	2350												

WV(V.DC) Cap(μ F)	100 (2A)		160 (2C)		200 (2D)		250 (2E)		350 (2V)		400 (2G)		450 (2W)	
	Size	Ripple	Size	Ripple	Size	Ripple	Size	Ripple	Size	Ripple	Size	Ripple	Size	Ripple
0.47	5x11	9					6.3x11	12	6.3x11	12				
1	5x11	15					6.3x11	17	6.3x11	18	6.3x11	18	8x11.5	15
2.2	5x11	21					6.3x11	30	8x11.5	31	10x12.5	31	10x12.5	25
3.3	5x11	30			6.3x11	36	8x11.5	43	10x12.5	45	10x12.5	41	10x16	33
4.7	5x11	35	6.3x11	43	8x11.5	50	8x11.5	53	10x12.5	55	10x16	55	10x20	42
10	5x11	60	8x11.5	77	10x12.5	80	10x16	90	10x20	95	12.5x20	85	12.5x20	67
22	6.3x11	98	10x16	125	10x20	135	12.5x20	150	12.5x25	175	12.5x25	170	16x25	115
33	8x11.5	140	10x20	170	12.5x20	200	12.5x20	200	16x25	220	16x25	220	16x31.5	155
47	10x12.5	185	12.5x20	210	12.5x20	220	12.5x25	240	16x31.5	260	16x31.5	275	16x35.5	185
100	10x20	290	12.5x25	320	16x25	340	16x31.5	400	18x40	415	18x40	415		
220	12.5x25	560	16x35.5	580	18x35.5	580								
330	12.5x25	690	18x35.5	700										
470	16x25	880												
1000	18x40	985												