

Features

- Yellow colored transparency lens type
- $\phi 3\text{mm}$ (T-1) all plastic mold type
- Low power consumption

Outline Dimensions

unit : mm

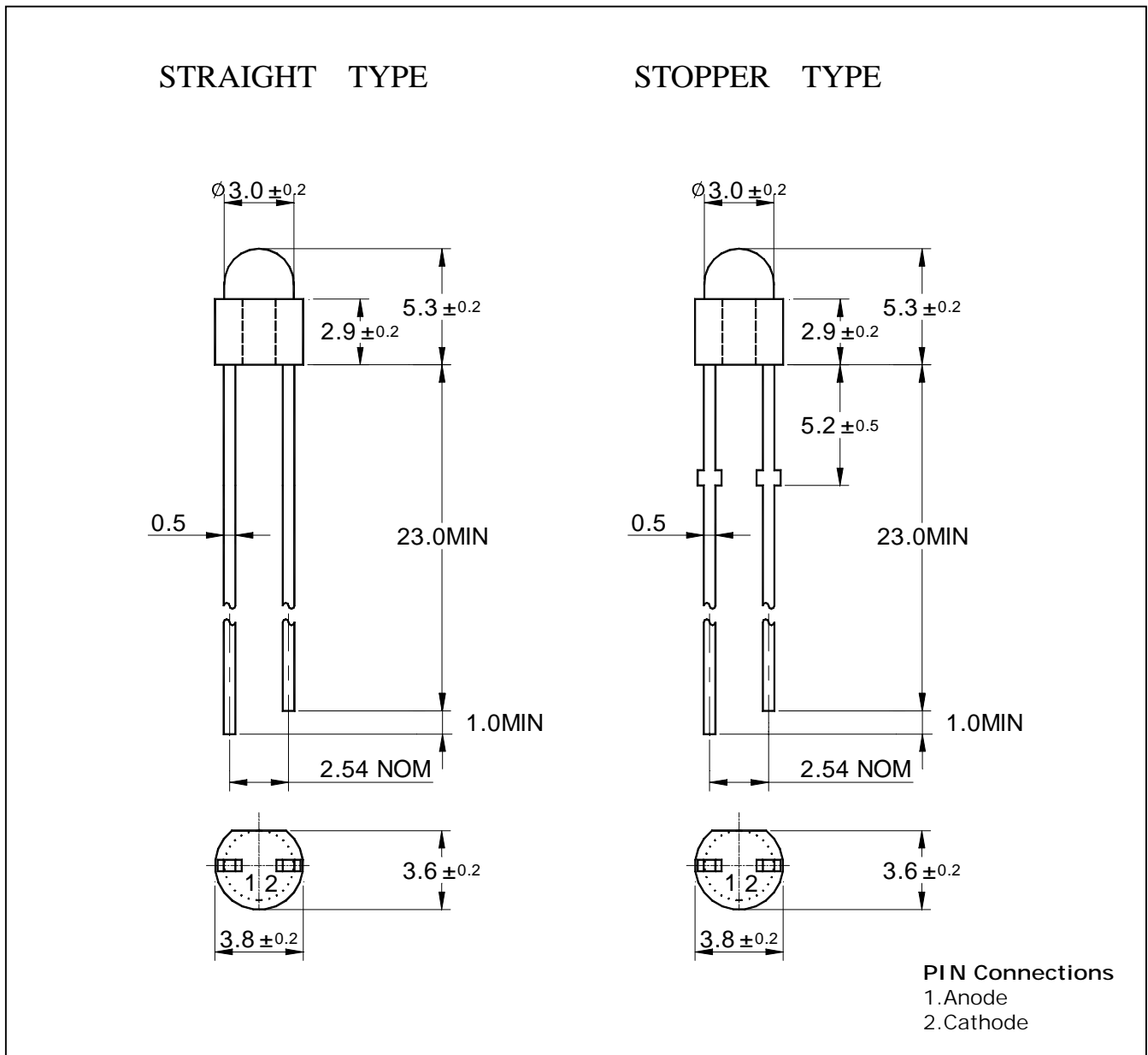

Absolute maximum ratings

| Characteristic | Symbol | Ratings | Unit |
|--------------------------------------|-----------|-------------------|------|
| Power Dissipation | P_D | 85 | mW |
| Forward Current | I_F | 30 | mA |
| * ¹ Peak Forward Current | I_{FP} | 50 | mA |
| Reverse Voltage | V_R | 4 | V |
| Operating Temperature | T_{opr} | -25 85 | |
| Storage Temperature | T_{stg} | -30 100 | |
| * ² Soldering Temperature | T_{sol} | 260 for 5 seconds | |

*1. Duty ratio = 1/16, Pulse width = 0.1ms

*2. Keep the distance more than 2.0mm from PCB to the bottom of LED package

Electrical Characteristics

| Characteristic | Symbol | Test Condition | Min | Typ | Max | Unit |
|---------------------------|----------------|---------------------|-----|----------|-----|------|
| Forward Voltage | V_F | $I_F = 20\text{mA}$ | - | 2.0 | 2.7 | V |
| Luminous Intensity | I_V | $I_F = 20\text{mA}$ | 15 | 40 | - | mcd |
| Peak Wavelength | λ_P | $I_F = 20\text{mA}$ | - | 585 | - | nm |
| Spectrum Bandwidth | | $I_F = 20\text{mA}$ | - | 30 | - | nm |
| Reverse Current | I_R | $V_R = 4\text{V}$ | - | - | 10 | uA |
| * ³ Half angle | $\theta_{1/2}$ | $I_F = 20\text{mA}$ | - | ± 22 | - | deg |

*3. $\theta_{1/2}$ is the off-axis angle where the luminous intensity is 1/2 the peak intensity

Characteristic Diagrams

Fig. 1 $I_F - V_F$

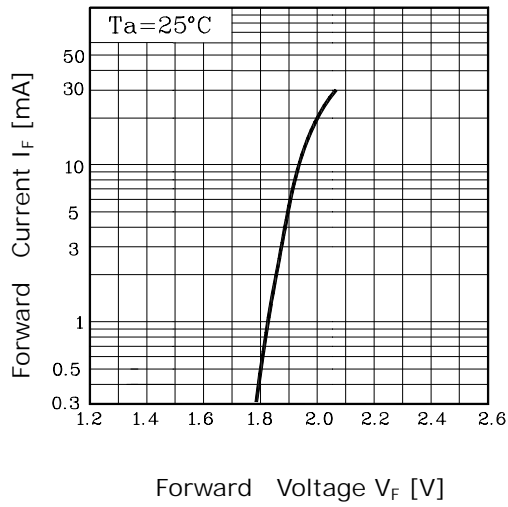

Fig. 2 $I_V - I_F$

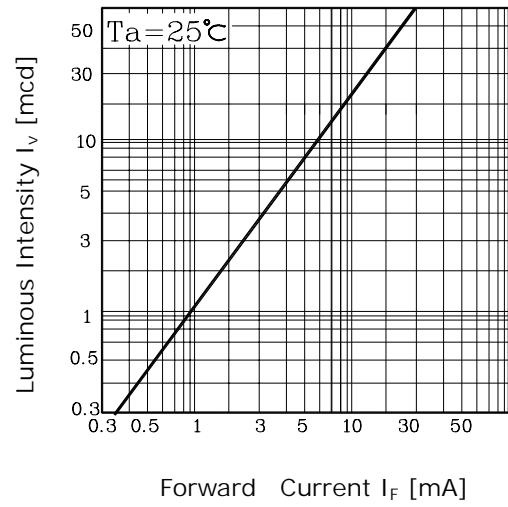

Fig. 3 $I_F - T_a$

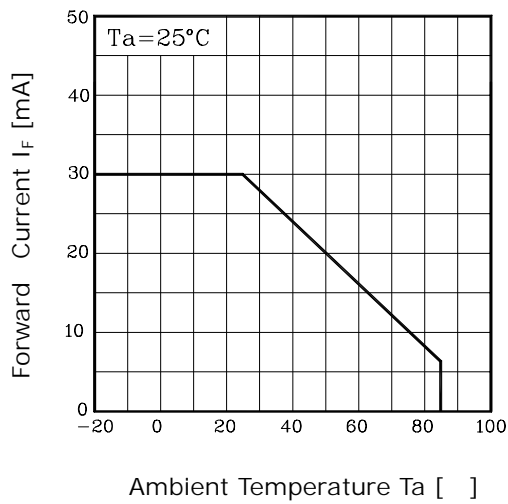

Fig. 4 Spectrum Distribution

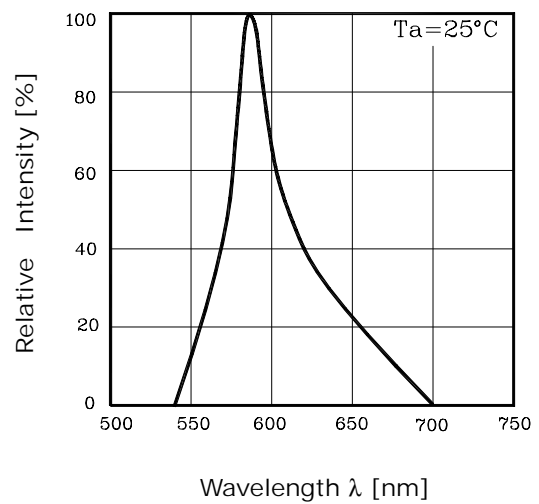

Fig. 5 Radiation Diagram

