

**Features**

- Red colored diffusion lens type
- $\phi 5\text{mm}$ (T-1 $\frac{3}{4}$ ) all plastic mold type
- Available on tape and reel

**Outline Dimensions**

**unit : mm**

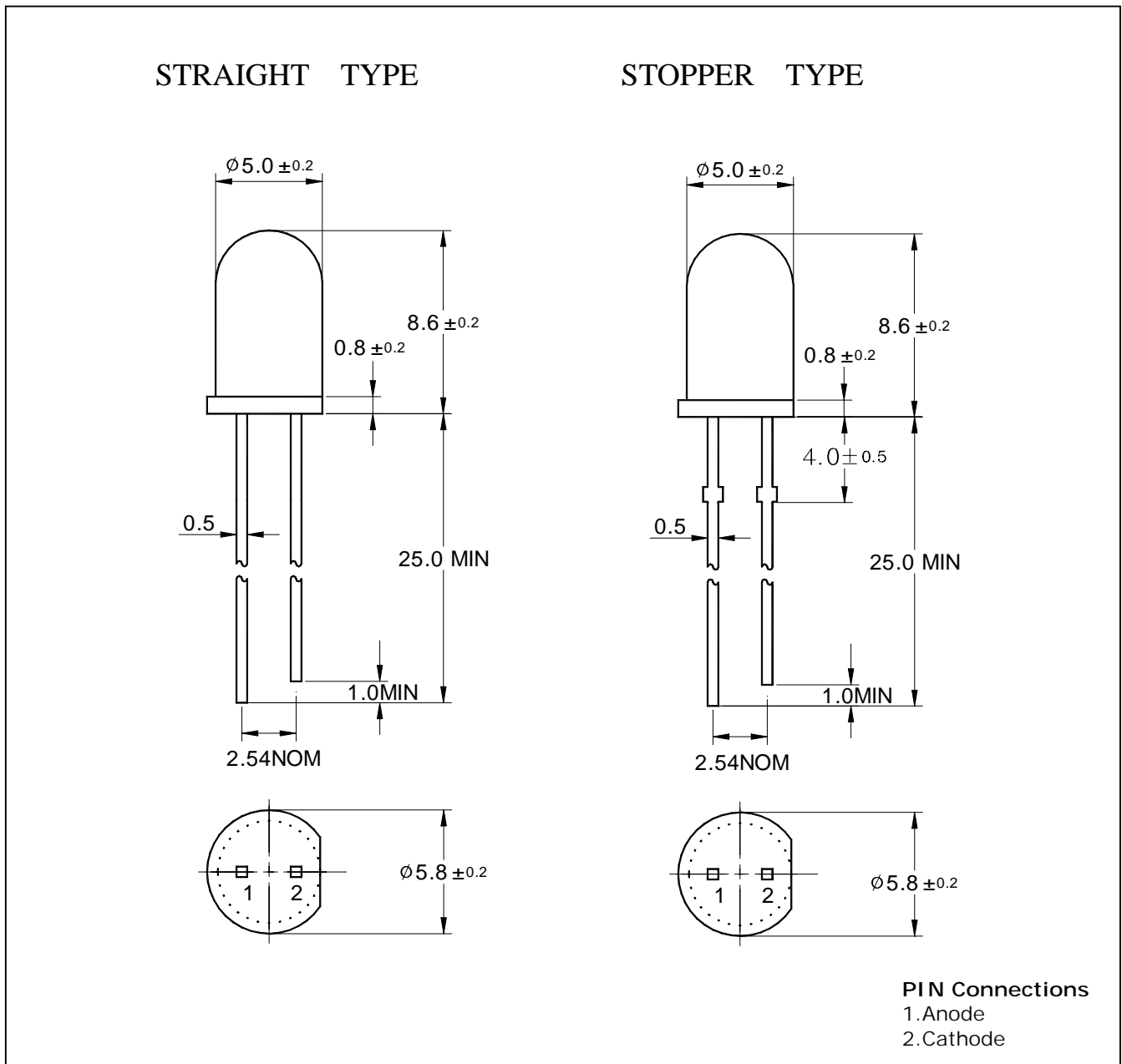

## Absolute maximum ratings

Characteristic	Symbol	Ratings	Unit
Power Dissipation	$P_D$	23	mW
Forward Current	$I_F$	10	mA
*1Peak Forward Current	$I_{FP}$	50	mA
Reverse Voltage	$V_R$	4	V
Operating Temperature	$T_{opr}$	-25 85	
Storage Temperature	$T_{stg}$	-30 100	
*2Soldering Temperature	$T_{sol}$	260 for 5 seconds	

\*1. Duty ratio = 1/16, Pulse width = 0.1ms

\*2. Keep the distance 2.0mm from PCB to the bottom of LED

## Electrical Characteristics

Characteristic	Symbol	Test Condition	Min.	Typ.	Max.	Unit
Forward Voltage	$V_F$	$I_F = 5\text{mA}$	-	1.9	2.3	V
Luminous Intensity	$I_V$	$I_F = 5\text{mA}$	2	5	-	mcd
Peak Wavelength	$\lambda_p$	$I_F = 5\text{mA}$	-	700	-	nm
Spectrum Bandwidth		$I_F = 5\text{mA}$	-	100	-	nm
Reverse Current	$I_R$	$V_R = 4\text{V}$	-	-	10	uA
*3Half angle	$\theta_{1/2}$	$I_F = 5\text{mA}$	-	$\pm 20$	-	deg

\*3.  $\theta_{1/2}$  is the off-axis angle where the luminous intensity is 1/2 the peak intensity

Characteristic Diagrams

Fig. 1  $I_F - V_F$

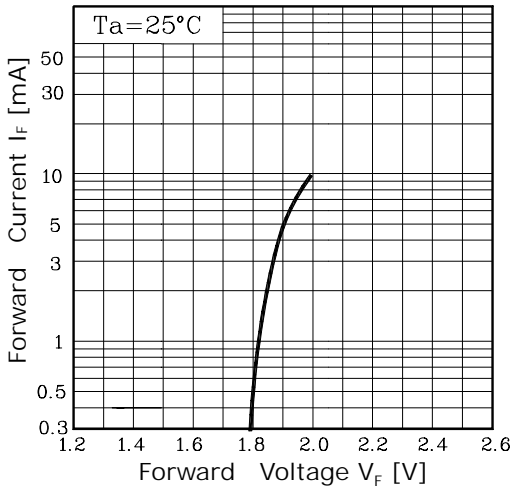

Fig. 2  $I_V - I_F$

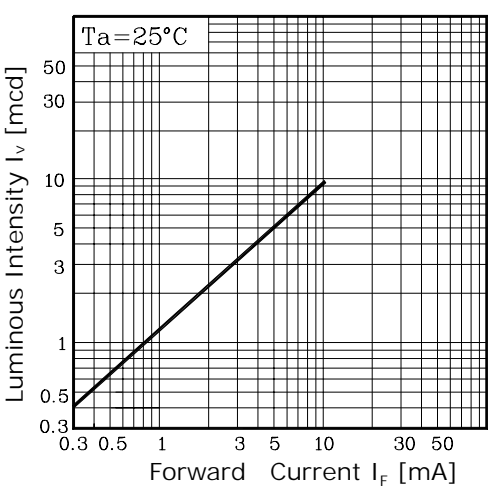

Fig. 3  $I_F - T_a$

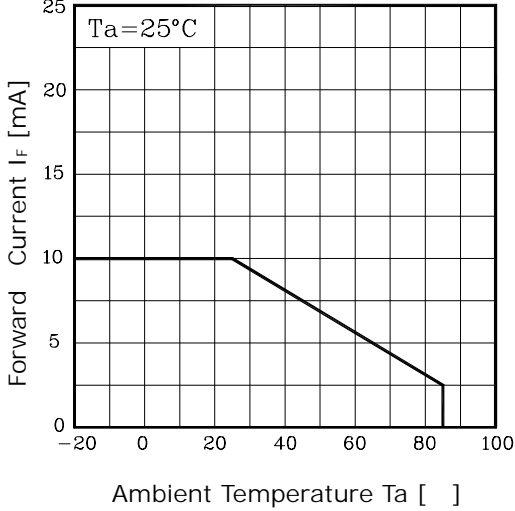

Fig. 4 Spectrum Distribution

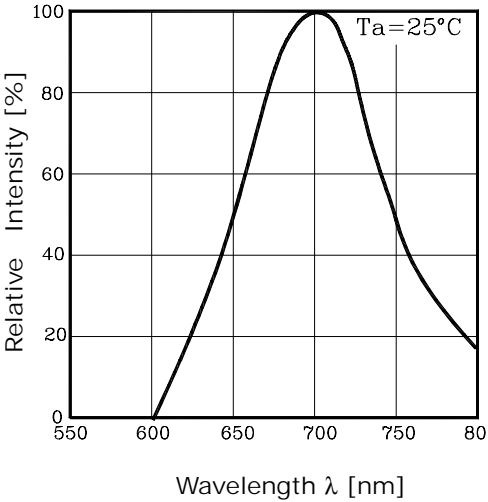

Fig. 5 Radiation Diagram

