

Features

- Green Colored diffusion lens type
- $\phi 5\text{mm}$ (T-13/4) all plastic mold type
- Low power consumption

Outline Dimensions

unit : mm

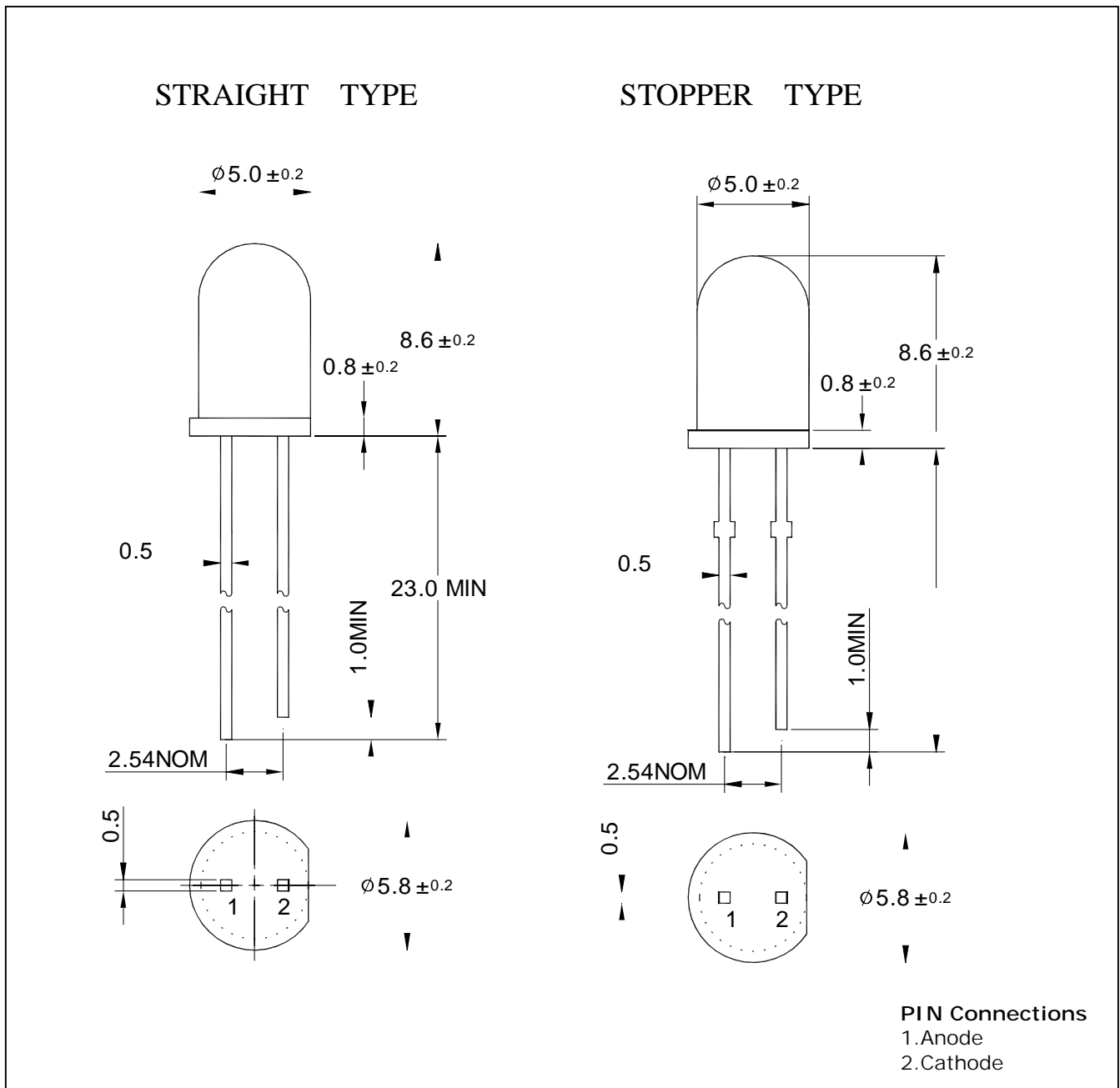

Absolute maximum ratings

Characteristic	Symbol	Ratings	Unit
Power Dissipation	P_D	85	mW
Forward Current	I_F	30	mA
*1Peak Forward Current	I_{FP}	50	mA
Reverse Voltage	V_R	4	V
Operating Temperature	T_{opr}	-25 85	
Storage Temperature	T_{stg}	-30 100	
*2Soldering Temperature	T_{sol}	260 for 5 seconds	

*1.Duty ratio = 1/16, Pulse width = 0.1ms

*2. Keep the distance more than 2.0mm from PCB to the bottom of LED package

Electrical Characteristics

Characteristic	Symbol	Test Condition	Min.	Typ.	Max.	Unit
Forward Voltage	V_F	$I_F = 20\text{mA}$	-	2.1	2.8	V
Luminous Intensity	I_V	$I_F = 20\text{mA}$	5	8	-	mcd
Peak Wavelength	λ_P	$I_F = 20\text{mA}$	-	570	-	nm
Spectrum Bandwidth		$I_F = 20\text{mA}$	-	30	-	nm
Reverse Current	I_R	$V_R = 4\text{V}$	-	-	10	μA

Characteristic Diagrams

Fig. 1 $I_F - V_F$

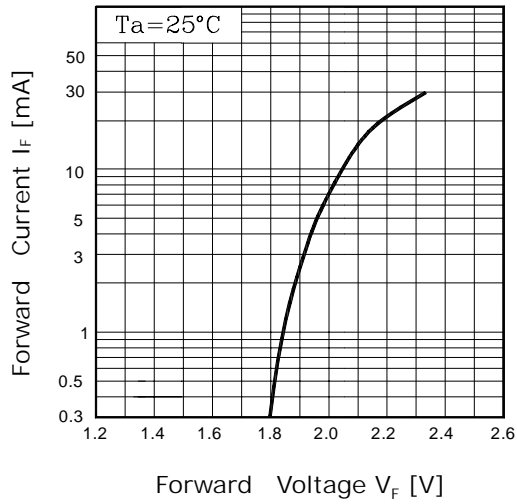

Fig. 2 $I_V - I_F$

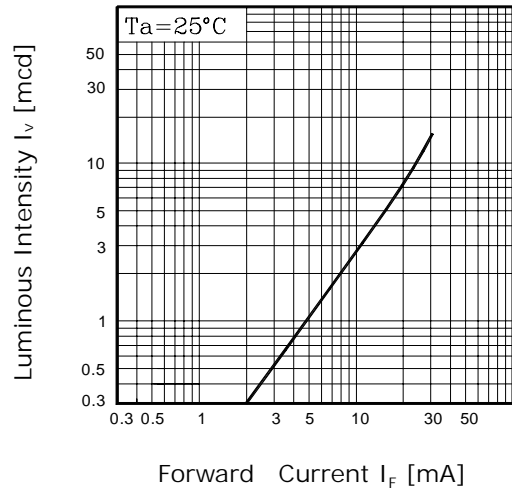

Fig. 3 $I_F - T_a$

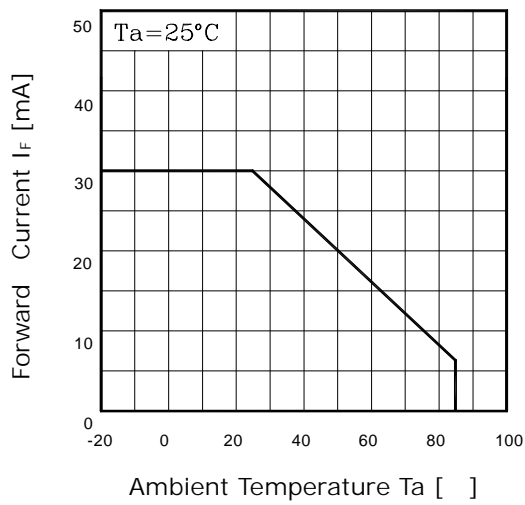

Fig.4 Spectrum Distribution

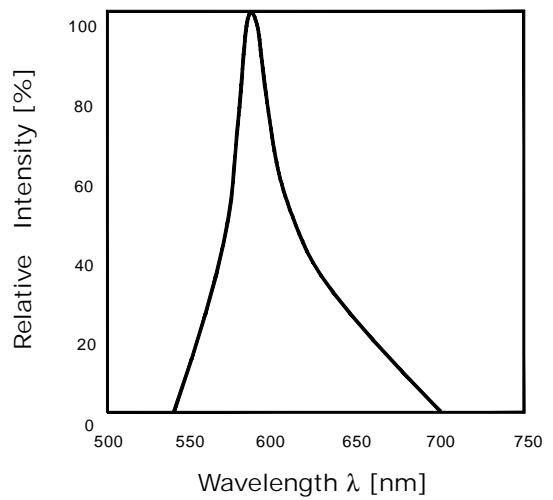

Fig. 5 Radiation Diagram

